

JBL

GRAND TOURING SERIES



**2/1 CHANNEL
AUTOMOTIVE POWER AMPLIFIER**

GTS100X OWNER'S MANUAL

GENUINE JBL

Introduction	3
Features	4
About Installation	4
Quick Start	5
System Design Using the GTS100x	6
Speakers	6
Signal Sources	6
Other Components	7
Typical Applications	8
Installation and Use	10
Installation Precautions	10
Physical Installation	11
Controls and Connectors	12
Mounting Instructions	13
Wiring	14
Power Supply Connections	15
+12V Battery Wire	15
Ground Wire	15
Remote Turn-On Wire	16
Audio Input Connections	17
Line-Level Input Connection	17
Input-Mode Switch	17
Speaker-Level Input Connections	18
Simultaneous Speaker-Level and Line-Level Inputs ..	19
Speaker Connections	20

Operation	23
Gain Adjustments	23
Other Characteristics	24
Solving Noise Problems	26
Maintenance	29
Additional System Configurations for Add-On or Upgrade . . .	30
In Case of Difficulty	32
Specifications	34
Warranty Terms	35

Owner's Warranty Information

Model Number _____

Serial Number _____

Dealer Name _____

City, State, Zip _____

Sales Receipt Number _____

Date of Purchase _____

Introduction



Thanks for purchasing your new GT series automotive amplifier. The GT series amplifier you have chosen includes many unique features to enhance its performance and utility. The power amplifier circuitry is a fully discrete design notable for low distortion and unusually clean and clear reproduction quality. Your GT series amplifier will easily connect to virtually any car audio system, whether it is factory installed or purchased separately.

In addition to conventional preamp-level inputs, this model features JBL's Universal Interface design, which facilitates simple connection to factory radios with the low distortion that is usually only associated with preamp-level connection. With Universal

Interface, a factory radio can be used either as the main music source or combined with a CD changer which includes volume control capability, simultaneously connected directly to the amplifier.

By providing this two-unit direct connection, Universal Interface circuitry eliminates the need for an FM modulator to connect a CD player to factory radios, improving the fidelity of digital playback.

Also, when using a high-powered (BTL) radio through the speaker-level inputs, Common Sense turn-on circuitry senses the common-mode voltage present on the radio's speaker wires and turns the amplifier on without an additional "remote" wire. When the speaker-level inputs

are used exclusively, the preamp-level inputs may be converted to preamp-level outputs to drive additional amplifiers or signal processors. In addition, the built-in active crossover provides either high-pass or low-pass operation. This lets your GT series amplifier power either subwoofer or main speakers in a bi-amplified system, without the expense of an additional crossover.

Features

- Bridgeable 2/1 Channel Operation
- Simultaneous Stereo + Mono Operation
- Built-in Staggered 18dB/Octave 100Hz High-Pass and 80Hz Low-Pass Crossover
- No Current Limiting
- Oversized Floating Rail MOSFET Switch-Mode Power Supply
- Common Sense 2-Way Turn-On
- Stealth Remote Silent Turn-On Circuitry with Power-On Indicator
- Continuously Adjustable Gain Controls
- Capable of Single-Ended Operation Into 2-Ohm Loads
- Fully Complementary, Direct-Coupled, Discrete Power Amplifier Circuitry
- Gold-Plated RCA Input Connectors
- Preamp Output Capability
- Convenient Easy-Disconnect Power and Speaker Connections
- Third Order (18dB per Octave), Capacitive/Inductive Power-Supply Filtering
- Input Mode Switching
- Made in USA

About Installation

Although the GTS100x was designed to make installation as easy as possible, it is a sophisticated product that requires proper installation to realize its full performance potential. Skill with tools, an understanding of basic electronics, and experience with car stereo installation are needed to properly install this amplifier. If you feel you do not have the necessary knowledge and skills, we strongly recommend that the installation be done by your authorized JBL dealer. If the GTS100x is installed by a qualified JBL dealer, we will double the length of your warranty to two years from date of purchase. If you choose to install the GTS100x yourself, read all of

the information in this manual before you start the installation. Pay particular attention to the safety precautions and notes. It will save potential problems later if you take a few minutes to plan the complete installation before you start. The routing of wires, the power supply connection points, and the mechanical installation of the unit should be completely thought out before you begin. Work carefully and check each step as it is performed. Before operating the amplifier, recheck the entire installation to be sure that each connection is correct, properly insulated and secure.

Quick Start

Recommended for experienced professional installers only!

1. Disconnect the negative cable from the battery. Note: If the vehicle's radio features a code-type security system, make certain you know the code before disconnecting the battery!
2. Mount the amplifier to the desired location using four screws.
3. Run a minimum AWG #10 power cable complete with a 20-amp fuse (not included) directly from the positive +12V battery terminal to the desired amplifier location. Keep the fuse to within 5" of the battery terminal, and before the wire runs through any metal partition.

Note: All wiring connections should be made either by soldering with heatshrink tubing insulation or with high-quality crimp-type insulated connectors installed with a good crimping tool. Soldering crimp connections is recommended to further enhance connection reliability. Never use wire-nuts, insulation-displacement connectors (i.e., ScotchLok type), or "twist and tape" connections. Do not use electrical tape; it will loosen with age and extreme temperatures. Never leave bare wire exposed.

4. Connect power wiring as shown in the Wiring Diagram on page 14, using the supplied power harness.
5. Connect the outputs from the signal source to the appropriate inputs of the amplifier according to the Wiring Diagram (page 14) with either high-quality low-level signal cables with RCA plugs, with the supplied speaker-level input connector, or both.
6. Connect the speakers to the amplifier according to the wiring diagram on page 14.
7. Turn the input sensitivity adjustment to the 1/4 position.
8. Set the input level switch to "line" if you are using the line-level (preamp) inputs.
9. Set the crossover switch as desired.
10. Set the input mode switch to stereo, left + right or right input only operation.
11. Reconnect the negative battery cable.
12. Turn on the signal source at a low volume level and check for the correct output from each speaker.
13. Adjust the amplifier gain control, using the procedure described in the Gain Adjustments section on page 23.
14. Read the rest of the manual to get maximum use and enjoyment from your amplifier.

System Design Using the GTS100x

06

Speakers

When used in the non-bridged mode, the GTS100x can easily drive 2-ohm speaker loads. When only one speaker is connected to each channel, virtually any common speaker may be used. When two speakers are connected in parallel to a given channel, each speaker must have a minimum impedance of at least 4 ohms to ensure that the combined load does not drop below 2 ohms. Although the amplifier will not be damaged, load impedances lower than 2 ohms will eventually cause the amplifier to overheat, activating the protection circuits and causing the unit to shut off until it cools down sufficiently.

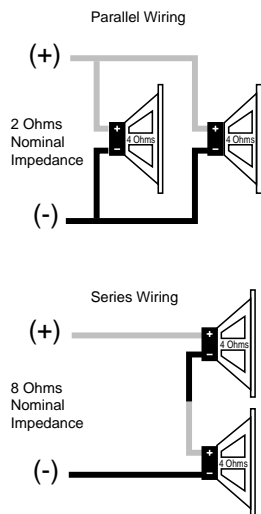

When the GTS100x is in bridged mode, the combined impedance of the speaker (or speakers) connected to the bridged channel should be at least 4 ohms. As in the example just mentioned, sustained operation of the GTS100x in bridged mode with less than 4 ohms will likely cause overheating. If monaural operation is desired, and two 4-ohm speakers are used, it is best to connect each speaker to an individual amplifier channel and use the "L+R" mode on the input-mode switch to provide monaural operation.

The GTS100x must not be used with speakers that have either one of their input terminals wired to the frame of the speaker or to the chassis of the vehicle.

Signal Sources

The low-level preamp outputs of any radio/tape deck, CD player or preamp/ equalizer so equipped can drive the GTS100x. The Gain control of the GTS100x is used to match the amplifier to the output voltage of the source. This matching is important to keep noise low and is explained in the Gain Adjustments section of this manual (page 23).

Thanks to Universal Interface circuitry, the GTS100x can also be connected to power amplifiers, radios or equalizers that are equipped with only speaker

outputs by connecting them through the speaker-level input connector. Inside the GTS100x, the speaker-level and preamp-level inputs are connected through a mixing circuit, which allows them to be used simultaneously. Therefore, a low-level source, such as a CD player equipped with preamp controls (Volume, Balance, Bass, Treble) may be connected to the preamp-level inputs at the same time as a powered radio/tape unit is connected to the speaker-level inputs. This provides a higher performance alternative to an FM Modulator connection when

you wish to add CD capability to a factory-installed cassette radio. Switching from one source to the other is as simple as turning the desired source on and turning the undesired one off — no additional switches or relay connections are needed.

Other Components

The system options of the GTS100x are numerous. All JBL amplifiers are designed with sufficient adjustment range to match with the accepted “normal” voltages and impedances used by virtually all car audio components. With very few exceptions, the GTS100x will match correctly to any equipment you already have.

Typical Applications

The following diagrams show the most common basic system configurations using the GTS100x. More elaborate systems are formed by using a combination

of these "building blocks." For additional ideas, refer to the "Additional System Configurations for Add-On or Upgrade" section on page 30.

Application 1

Stereo Full-Range or Subwoofer Operation

Full-Range Operation

Crossover Switch	Input Mode Switch	Line Switch
Off	Stereo	In

Subwoofer Operation

Crossover Switch	Input Mode Switch	Line Switch
Low	Stereo	In

Main speakers are driven by head unit or additional amplifier.

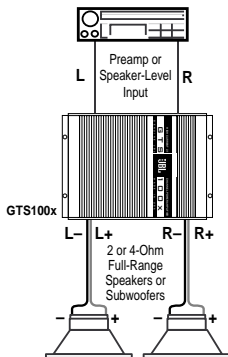

Application 2

Bridge-Mode Operation

Single Amplifier:
Subwoofer Operation (Mono)

Amp	Crossover Switch	Input Mode Switch	Line Switch
B	Low	L + R	In

Main speakers are driven by head unit or additional amplifier.

Dual Amplifier:
Subwoofer Operation (Stereo)

Amp	Crossover Switch	Input Mode Switch	Line Switch
A+B	Low	R	In

Full-Range Operation (Stereo)

Amp	Crossover Switch	Input Mode Switch	Line Switch
A+B	Off	R	In

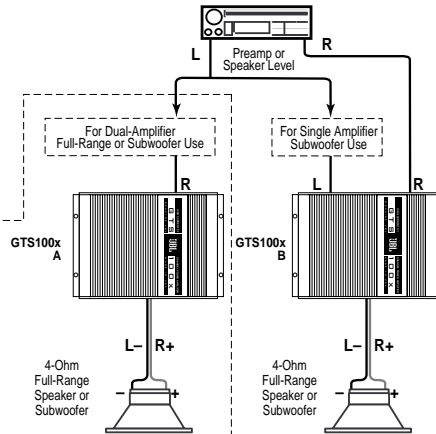

Application 3

Biampified, Three-Channel Subwoofer/Satellite System

Amp	Crossover Switch	Input Mode Switch	Line Switch
A	High	Stereo	In
B	Low	L + R	In

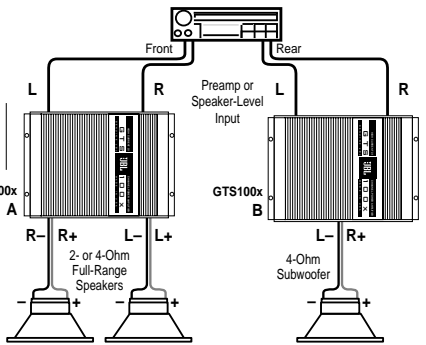

Stereo Subwoofers may be used by configuring GTS100x-B as shown in **Application #1**

Application 4

Biampified System Using Preamp Output Capability

Amp	Crossover Switch	Input Mode Switch	Line Switch
A	High	Stereo	Out
B	Low	L + R	In

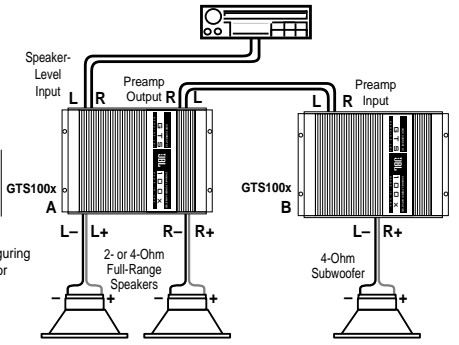

Stereo Subwoofers may be used by configuring GTS100x-B as shown in **Application #1** or by using dual GTS100xs as shown in **Application #2**

Installation and Use

10

Installation Precautions

Before beginning the installation of the amplifier, read the following precautions carefully. Failure to heed these warnings could result in **personal injury or damage to property**.

- The GTS100x should be installed only in vehicles that have 12-volt negative ground electrical systems. Connection to other types of electrical systems may damage the amplifier and/or the vehicle's electrical system.
- Before beginning the installation, disconnect the negative (ground) cable from the vehicle's battery. This will prevent accidental short circuits while working on the installation. Reconnect the cable only after

the installation is complete and the wiring has been carefully checked to be sure there are no exposed wires or short circuits and everything is properly and securely connected. Note: If the vehicle's radio features a code-type security system, make certain you know the code before disconnecting the battery!

- Work in an area that is well ventilated.
- Wear eye protection whenever cutting, drilling or filing any parts of the vehicle.
- Wear ear protection when using high-speed drills, saws, sanders, or grinders. We want you to be able to enjoy the system once it is installed.
- Before cutting or drilling any holes in the vehicle, inspect the area carefully to be sure there are no electrical wires, hydraulic brake lines, fuel lines, or fuel tanks that may be damaged while doing so. Such components may be hidden within double-walled panels or structural members of the vehicle, so be extremely cautious.
- Do not bypass or modify the fuse on the chassis of the amplifier. Do not replace the fuse with one rated for higher current levels. Doing so could result in damage to the amplifier and the vehicle's electrical system. Repeated blowing of the power supply fuse indicates a fault within the amplifier or problems in the installation.
- An additional power supply fuse (not included) should be located as close as possible to the battery on the +12V wire to minimize the chance of electrical system damage or fire in the event of a short circuit in the power supply wire.

Physical Installation

There are several factors to consider when selecting a mounting location for the GTS100x.

- It must be solidly mounted in a place where it will not be subjected to excessive shock and vibration.
- Under no circumstances should the amplifier be mounted where it will be exposed to moisture or extreme heat.
- Try to mount the amplifier where the main +12 volt power supply wire, which must be connected directly to the battery, can be kept relatively short.
- The GTS100x must be mounted in a place where air can circulate around the fins on the chassis. Good air circulation around the amplifier will make it operate at lower temperatures and reduce the chance of the thermal protection circuits being triggered. The installation positions that provide the most efficient air circulation around the amplifier are shown at right.
- Use a mounting location that allows access to the wiring connections and level adjustments. This allows the unit to be mounted before these connections and adjustments are made. If the amplifier must be mounted in an inaccessible location, it may be easier to mount it after the wiring connections and level adjustments are complete.

BEST-Vertical Mounting

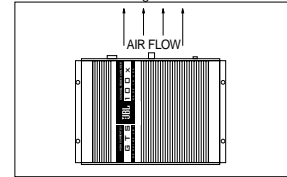

GOOD-Horizontal Mounting

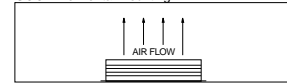

NEVER-Mount Upside Down

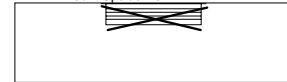

Controls and Connectors

1. Line-Level RCA Inputs – Use these connectors for line (pre-amp)-level input to the amplifier. When speaker inputs are used, this connector can be converted for use as a line-level output by setting the “Line” switch to “Out.”

2. Line Selector – This switch sets the line-level connectors for either input or output. Set switch to “In” for normal line-level input operation. Set the switch to “Out” to use the line-level connector for line-level outputs to drive other amplifiers or signal processors when using the speaker-level inputs.

3. Gain Control – Use this control to adjust the input sensitivity of the amplifier. See the “Gain Adjustments” section on page 23 for tips on proper setup.

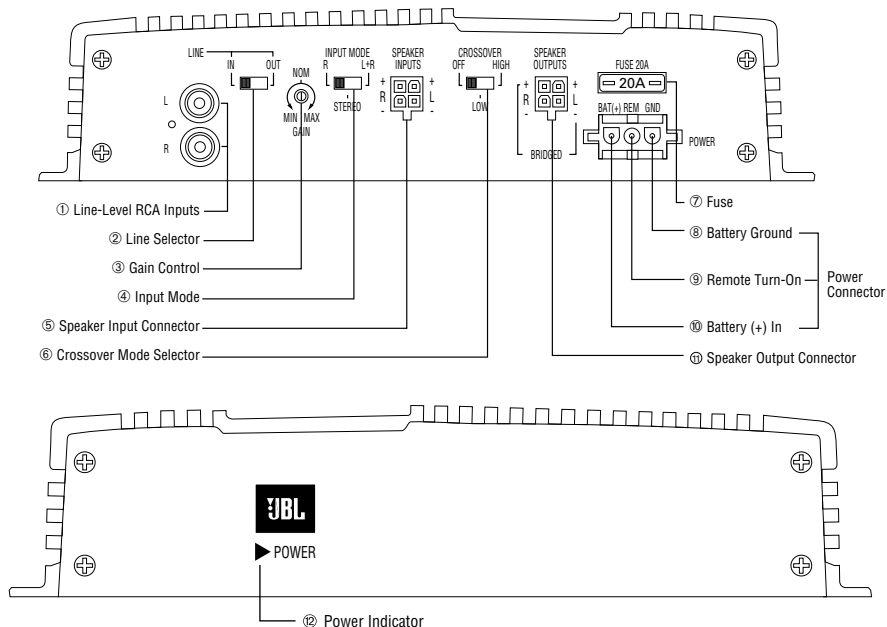

4. Input Mode Selector – This switch is used to set the input mode for both preamp and speaker-level inputs. Set this switch to “Stereo” for normal operation using both left and right inputs. Set this switch to “R” to drive both the left and right channels with only a single input on the right channel. Set this switch to “L+R” to sum the left and right inputs for a mono output on both amplifier channels.

5. Speaker Input Connector – Use this connector for speaker-level input signals. A wire harness is supplied for this connector. See the “Audio Input Connections” section (page 17) for wiring instructions. This input also includes JBL’s Common Sense input circuitry which turns the amplifier on as soon as a high-powered head unit connected to this input is turned on.

6. Crossover Mode Selector – This switch controls the built-in crossover. Set the switch to “Off” for full-band operation. Set this switch to “Low” to activate the 80Hz low-pass filter on the amplifier (for subwoofer use). Set the switch to “High” to activate the 100Hz high-pass filter for use with satellite speakers. Note that the filter does not affect the line-level outputs on the amplifier.

7. Fuse – 20-amp ATC-type fuse.

8., 9., 10. Power Connector – Connection for included power wire harness. See “Power Supply Connections” on page 15 and the wiring diagram on page 14 for information on wire color codes and proper connections.

11. Speaker Output Connector – Connection for included speaker output harness. See “Speaker Connections” section on page 20 for information on wire color codes.

12. Power Indicator LED – Power indicator light glows for normal operation when the amplifier is activated by either the remote or common sense turn-on circuits.

Mounting Instructions

Place the amplifier in the installation location. Use a pen or pencil to mark the four mounting screw hole locations. Set the amplifier aside and drill the holes for the mounting screws. (Note: If the surface you are mounting the amp to is covered with carpeting or upholstery, cut a small “x” in the material at each screw hole location before drilling the holes. This will help prevent tearing or stretching of the material and keep carpet fibers from being pulled out.) Set the amplifier in position and align the mounting holes with the holes previously drilled. Put washers on the four sheet metal screws provided and drive them into the mounting panel. Tighten the screws evenly until the unit is solidly mounted.

Wiring

Proper wiring of the GTS100x and the associated components is extremely important for proper performance and long-term reliability. Using the proper type of wire is very important. If a specific type of wire should be used for a certain application, it will be noted.

All wiring connections should be made either by soldering with heatshrink tubing insulation or with high-quality crimp-type insulated connectors installed with a good crimping tool. Soldering crimp connections is recommended to further enhance connection reliability. Never use wire-nuts, insulation-displacement connectors (i.e., ScotchLok type), or "twist and tape" connections. Do not use

electrical tape; it will loosen with age and extreme temperatures. Never leave bare wire exposed. Route the wiring through the car carefully. Do not allow wires to lay against sharp sheet-metal edges or any other surfaces that might wear away or cut through the insulation of the wire. Use insulated strain reliefs, rubber grommets and plastic tubing to protect the wires whenever they are run through sheet-metal panels or are placed where they might be pulled or damaged.

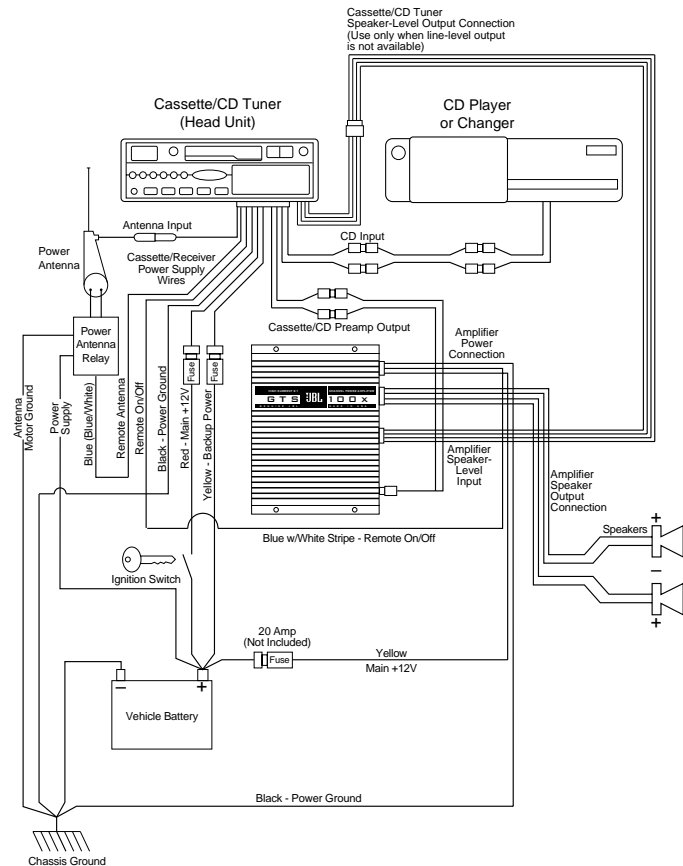

Power Supply Connections

The power input and remote turn-on wires are connected to the GTS100x via the power connector on the end of the amplifier. Use the included wire harness for connections. In some cases, such as a custom competition installation, you may wish to make your own custom power harness. The part numbers of the mating connector and terminals are listed in the specifications section of the manual, and are common parts available at many electronics parts retailers. Please do not call JBL for these; we stock only the pre-made harness supplied with the amplifier.

+12V Battery Wire (Yellow)

- Connect the yellow wire directly to +12 volt terminal of the battery.

- If it is necessary to extend the power wire, use 12 gauge or larger wire that is heat and oil resistant.
- The GTS100x will draw as much as 20 amps from the vehicle's electrical system, enough to overload conventional vehicle wiring. Therefore, the +12-volt power supply must be run directly from the positive side of the battery. **Do not connect to the vehicle's fuse block or to a wire feeding other accessories.**
- To prevent electrical system damage or fire, a fuse holder and fuse (not included, maximum 20A) must be installed in the power supply wire, as close to the battery as possible, and before the wire travels through the firewall or other metal panel.

Ground Wire (Black)

- Proper grounding is extremely important. It has a significant effect on the overall performance and noise level of the system. The ground wire must be solidly connected to a major sheet-metal structure of the vehicle. Usually the power supply ground wire can be connected to a sheet metal panel near the amp mounting location. Scrape all paint and primer off the sheet metal at the grounding point to ensure a good electrical connection. Attach the wire to the grounding point with a sheet-metal screw and lock washer (preferably a star lock washer) or a bolt/lock washer/nut set.
- In some vehicles, such as those that have non-metal bodies, it may be necessary to extend the power supply ground wire and connect it to a frame rail or even directly to the negative (-) terminal of the battery. Use heat- and oil-resistant 10 gauge or larger stranded copper automotive wire and crimp or solder and insulate the wire-to-wire connections. Keep the extension wire as short as possible. Solder or crimp a terminal on the end of the extension wire and connect it to the frame or battery terminal.

- When multiple amplifiers are installed in the system, it is often best to ground all of the amplifiers and signal processors to the same point to prevent noise pickup from a ground loop. In some unusual installations the noise level will be lower if the amplifier or amplifiers are grounded to the same point where the head unit is grounded. Use of heavy gauge wire for all grounding, even signal processors and head units, can also help to minimize possible noise pickup.

Remote Turn-On Wire (Blue with White Stripe)

Because the JBL GTS100x includes Common Sense two-way turn-on circuitry, you have two options for remotely activating the amplifier. When using the speaker-level inputs with a head unit that includes a BTL power amp, it is not necessary to connect the remote wire. The amplifier will automatically activate whenever you turn on the head unit. If the head unit is not of the high-power BTL type, Common Sense will not work. You will need to connect a remote wire as follows. If you are using the line-level inputs, follow the remote wire connections listed.

The remote power control system turns the GTS100x off when not in use to prevent discharging of the vehicle's battery. When +12 volts is applied to the remote wire, the amplifier is turned on. A red LED on the end panel of the amplifier lights whenever the amplifier is on. If the head unit has a +12 volt automatic antenna or amplifier remote activation wire, connect it to the blue/white wire of the GTS100x.

Some head units have no automatic antenna or power amp activation wire. Other decks have automatic antenna wires that are "on" only when the radio is used (the +12 volt signal is off when a tape is played). In such cases, connect the remote turn-on wire to an unused accessory terminal in the fuse block, or any other +12 volt source that is turned on and off with the vehicle's ignition switch. The remote on/off system draws negligible current, so a relatively small (18 or 20 gauge) extension wire may be used. Be sure to securely crimp or solder and insulate the wire-to-wire connections.

Audio Input Connections

Line-Level Input Connection

Proper wiring between the signal source, any other components in the system and the GTS100x will help to keep noise levels in the system low. Use high-quality, low-capacitance shielded wire. Keep the wire as short as possible. Do not splice shielded wires together. Do not run audio signal wires alongside power wires either for the amp or the vehicle's standard power wires. When wires are run for long distances, separate the audio signal wires from power supply wires or vehicle wiring harnesses as much as possible. When signal wires and power wires must cross, try to keep them perpendicular. Avoid routing any wires near accessories such as ignition control

modules, tachometers, fuel pumps or fan motors.

The line-level inputs of the GTS100x accept standard phono plugs (also called RCA plugs). The outputs of most head units, equalizers or crossovers also accept RCA connectors. If another type of connector is used, adapters or special cables may be needed. Proper wire and connectors can be obtained from any JBL authorized installation specialist.

NOTE: The GTS100x has a built-in 80Hz low-pass (subwoofer) crossover and a 100Hz high-pass (satellite) crossover. Be sure the crossover switch is properly set for the chosen system configuration (see the "Typical Applications" section on page 8 for suggestions). If you have any questions about how to set this switch, contact your local JBL dealer.

Input-Mode Switch

This switch is set according to the number of input channels connected to the amplifier and the desired mode of operation. See diagrams on pages 8 and 9 and the descriptions below for options.

Standard Operation – When using the GTS100x as a conventional stereo amplifier, simply connect the preamp-level source outputs directly to the two gold RCA connectors or connect the head unit speaker outputs to the speaker-level inputs with the input mode switch set to "Stereo." When using two sources, both the speaker and preamp-level inputs may be used simultaneously. Be sure to maintain left and right channel consistency.

Bridged Mode Operation – To select bridged mode operation, set the input mode switch in either the “R” only or “L+R” position. In the “R” position, signal from the right channel input is fed to both amplifier channels. In the “L+R” position, the signal from both channels is summed internally. When using a single GTS100x for mono mode fed with a stereo signal, it is best to use the “L+R” mode. When using a GTS100x for each channel, or when feeding a single GTS100x with a mono signal from an out-board crossover, use the “R” mode and connect your source input to the right channel input.

Simultaneous Stereo + Mono – For this connection, the Input Mode switch is left in the stereo position. Main speakers are connected normally to the left and right stereo outputs, and a center-channel or subwoofer speaker is connected in bridged mode. Refer to the diagram on page 21 in the “Speaker Connections” section for details.

Speaker-Level Input Connections

When speaker-level signal is used to drive the GTS100x, the signal goes into the amp through a special four-wire harness/connector (see the “Controls and Connectors” section, page 12). If extension wires are needed between the head unit output and the amplifier unit, use conventional speaker wire. Keep the wiring inside the passenger and trunk compartments and make the wires as short as possible. All connections should be securely crimped or soldered and insulated with heatshrink tubing. Use the color code of the input harness wires and the identification on the radio/tape deck output wires to be sure that left and right channels are correctly con-

nected and the positive/negative polarity of each channel is connected correctly. For example, the left positive output of the head unit must be connected to the left positive input of the GTS100x. The color codes for the speaker level input harness are as follows:

Speaker-Level Input Color Codes

Left (+): White
 Left (-): White with
 Black Stripe
 Right (+): Gray
 Right (-): Gray with
 Black Stripe

Simultaneous Speaker-Level and Line-Level Inputs

In some systems it may be desirable to use both the speaker-level inputs and line-level inputs simultaneously. For instance, if you have a stock head unit in your car, you may connect the speaker-level inputs of the head unit to the GTS100x. You may simultaneously connect a CD player equipped with preamp volume control to the preamp-level inputs of the GTS100x. The Universal Interface circuitry of the GTS100x will isolate the inputs from each other while mixing both signals. Therefore, switching from one source to the other is as simple as turning the unused source off and turning the desired source on. No other switches or relay boxes are needed.

When using this setup it is also possible, using the wiring setup shown at right, to allow either of the two sources to remotely turn on the amplifier. This is not necessary if the factory radio is of the high-power BTL type and is connected to the speaker-level inputs. The Common Sense turn-on circuit will activate the GTS100x when a powered source is used, and the conventional remote connection of the preamp-level source will activate the amp when it is used.

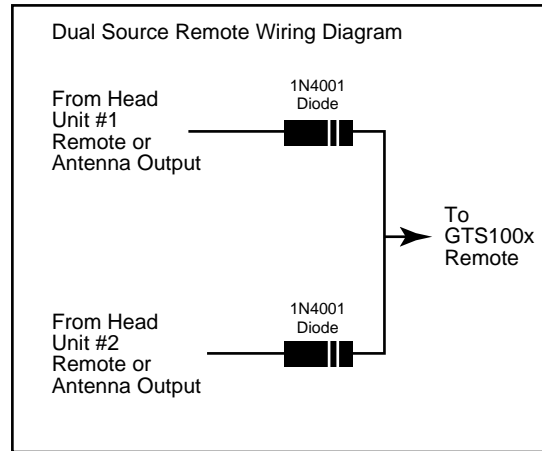

Speaker Connections

20

When connecting speaker wires, be sure that no uninsulated wire remains exposed and no loose strands of wire touch either an adjoining wire, terminal or metal surface. Securely crimp or solder all connections and insulate them with heatshrink tubing. Use high-quality 18 gauge or larger speaker wire for the amplifier-to-speaker connections. Larger wire or special high-performance speaker cables may improve the performance of some systems. Be very careful when speaker wire is routed through a door hinge area to door-mounted speakers. Use grommets and strain reliefs wherever necessary to prevent damage to the wires.

The proper speaker connection depends on whether the GTS100x is used bridged or stereo. The speakers are connected to the amplifier with the included wire harness. If you wish to purchase the raw connector to make a custom-length harness, the part number is listed in the Specifications section. This item is commonly available from local electronic parts distributors. Please do not call JBL for this part; we stock only the harness assemblies supplied with the amplifier.

To get proper bass response and stereo imaging, all the speakers in the system must be "in phase." The input terminals of the speakers will be marked in some way to identify positive and negative polarity. Make sure that the positive (+) speaker terminal is attached to the positive (+) amplifier connection in every speaker-to-amp connection. All two-conductor speaker wire has one conductor marked in some way so it can be easily traced.

The speaker output wire harness color codes are listed below:

Speaker Output Color Codes

Left (+): White
Left (-): White with
Black Stripe
Right (+): Gray
Right (-): Gray with
Black Stripe

Stereo Connection – Connect each speaker directly to the speaker output harness according to the color codes listed above. The input-mode switch should be set to "Stereo."

Simultaneous Stereo-Mono Connection Diagrams

A. Satellite/Subwoofer

Component Values for 4-Ohm Loudspeakers*

- High-Pass Satellite Crossover Frequency: 100Hz
- C: 300µF Capacitor 100V, Non-Polarized
- Subwoofer Low-Pass Crossover Frequency: 100Hz
- L: 6.2mH Air Core Inductor

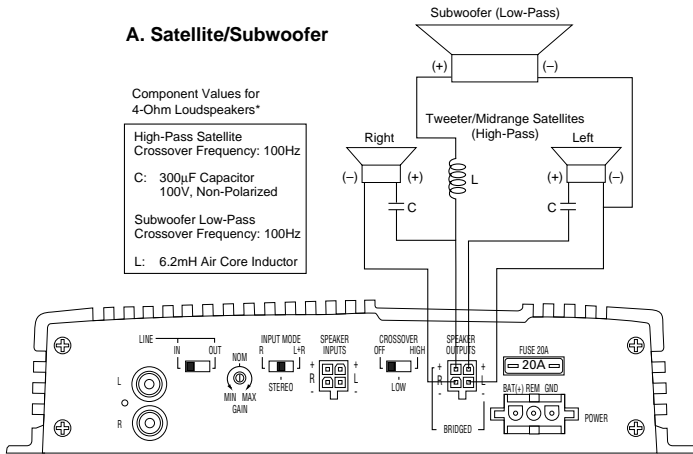

*You may scale the 100Hz values listed to a different desired frequency by using the following formulas:

$$\text{High-Pass: } \frac{100}{\text{desired frequency in Hz}} \times 300\mu\text{F} = \text{New Capacitor Value}$$

$$\text{Low-Pass: } \frac{100}{\text{desired frequency in Hz}} \times 6.2\text{mH} = \text{New Inductor Value}$$

B. Center Channel

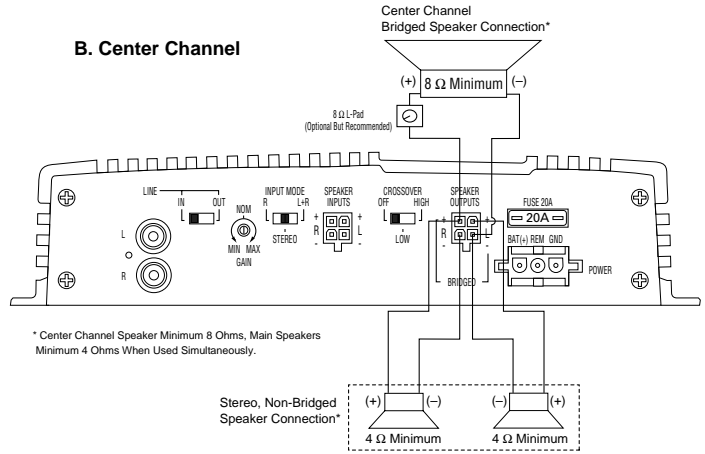

* Center Channel Speaker Minimum 8 Ohms, Main Speakers Minimum 4 Ohms When Used Simultaneously.

Stereo, Non-Bridged Speaker Connection

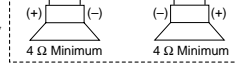

Bridged-Mode Connection –

Connect the loudspeaker positive (+) terminal to the RIGHT channel positive wire (Gray). Connect the loudspeaker negative (–) terminal to the LEFT channel negative wire (White with Black stripe). The input-mode switch should be set to “R” or “L+R.”

Simultaneous Stereo + Mono

Connection – The GTS100x may be used to drive a stereo pair of speakers with a mono (bridged) speaker at the same time. This is sometimes used for center-channel applications or for inexpensive subwoofer addition, essentially creating a three-channel system. However, unlike a true bi-amplified subwoofer connection, this system configuration does not provide for control of subwoofer-satellite

balance; it requires the use of a passive subwoofer crossover instead of the superior active circuitry already built into the GTS100x, and it does not separate the power amps driving the satellites from the amps driving the subwoofer. Therefore, this connection is best used for addition of a center-channel speaker, or as an interim step as you build up to a true bi-amplified subwoofer-satellite system. Connect the main pair of stereo speakers as in the stereo mode, connect the mono speaker as described for bridged-mode connection (see diagram on page 21). For use in center-channel applications, a

high-power “L-Pad” or power fader can be used to attenuate the center channel for proper level matching. For subwoofer-satellite use, connect a non-polarized capacitor in series with each main speaker, and a high-power inductor (coil) in series with the subwoofer. Your authorized JBL dealer will help you choose the correct values for your particular components. The input-mode switch should be set to “Stereo.”

Operation

Before operating the GTS100x, recheck all wiring connections to make sure they are correct and secure. Be sure that a 20-amp fuse (not included) is installed in the +12V line next to the battery. Reconnect the negative ground (-) terminal of the battery. Make sure that the input mode selector, crossover switch and preamp mode switch are properly set.

Gain Adjustments

The setting of the gain control on the GTS100x is important to ensure proper performance, low noise levels, and maximum reliability in the system. As a general rule, controls on components at the front end of the system (source, equalizers, electronic crossovers, etc.) should be set as high as possible, with the amplifier gain control set as low as

possible while still providing adequate volume levels. Using a high signal level from the source and a low gain setting on the amplifier will help keep background noise levels in the system low.

To adjust a system using a single amplifier, start with the amplifier input sensitivity controls fully counterclockwise. Some radio/tape decks have additional output level controls or switches. Set these to their maximum position. Set the level controls on any associated equipment such as equalizers and electronic crossovers to the maximum position or as recommended by the manufacturer. Set all Bass/Treble or equalizer controls to their centered or bypassed positions. While listening carefully to

the system output, adjust the volume control of the radio/tape deck to the point where you first begin to hear audible distortion. Reduce the level just to the point where the distortion goes away. This is the maximum undistorted output level of your head unit and signal processors, and should not be exceeded during use. If audible distortion does not occur, continue to increase the level until the head unit is turned all the way up. If this setting does not provide adequate volume levels, gradually increase (turn clockwise) the gain control of the GTS100x until the system plays as loud as necessary or when the first signs of distortion are heard.

When multiple amplifiers are used in the system, it is best to adjust the gain of the amplifier driving the main (usually front) speakers first. Then turn down the head unit's volume control to a comfortable level, and adjust the remaining amplifiers for the desired system balance. You will find this easiest to do by adjusting the amplifiers in the following order: 1) front channels, 2) rear channels, 3) subwoofers. Complex systems incorporating tri- or quad-amplification can be time-consuming to adjust. Your local authorized JBL installation specialist is the best person to help with such adjustment.

Other Characteristics

Turn-On Delay – When installed as described in this manual, the GTS100x will turn on and off with the head unit or the vehicle's ignition switch. When the amplifier is turned on, there is a time delay of several seconds (longer in cold weather) before the amplifier will produce sound. This eliminates the chance of annoying noises produced by the radio or signal processors being amplified and passed to the speakers when the system is first turned on.

Power Consumption – Operating the GTS100x when the vehicle is not running may discharge the battery. Under normal operating conditions, the unit will draw an average of 5 amps from the battery. At high volumes, the amplifier can draw as much as 20 amps for brief bursts. After even a short period of time, this current drain can discharge the battery to the point that it will not start the vehicle. Power consumption under "no signal" conditions is less than 1 amp for the GTS100x. Even this small power usage can discharge a battery over several hours' time. When the GTS100x is turned off, there is no current drawn from the battery despite the direct-to-battery power connection.

Overload Protection – The GTS100x incorporates elaborate protection circuitry to prevent damage to the amplifier circuitry and ensure reliable operation. This circuitry will turn the amplifier off in the event of overheating, a short circuit on the speaker output wiring, or improper power supply connections. If the amplifier cycles on and off, or does not work at all, a problem in installation or an abnormal electrical condition is indicated.

Check speaker wiring for short circuits or impedance loads significantly below 2 ohms (4 ohms in bridged mode). Check the power supply voltage at the input of the amplifier to be sure that it is normal, between 11 and 16 volts. Check that the power wires are not reversed. If the GTS100x is operated at very high power levels in a high ambient temperature situation, the unit may not be able to radiate all the heat generated by such operation. If the temperature of the amplifier reaches a level that could cause damage, the thermal overload protection circuit will turn the amplifier off. It will turn the amp back on

again when it cools off. Repeated activation of the protection circuits indicates that the system is being improperly operated or that the amplifier should be relocated to an area that either has a lower ambient temperature or that allows more air circulation around the unit.

Fuse Replacement – If the fuse on the GTS100x must be replaced, DO NOT use a fuse rated for higher current levels. The fuse size for the GTS100x is 20 amps. Exceeding the standard fuse size or bypassing the fuse holder will void the warranty and may cause serious damage. It is extremely rare for this fuse to blow. If it blows repeatedly, it is most likely that the amplifier has an internal problem that will need to be repaired by an authorized service center. The only external cause for this fuse to blow is reversed polarity of the power wire connections.

Solving Noise Problems

26

The power supply system of every vehicle has some electrical “noise” that is generated by the ignition system, the alternator, the accessories, and their wiring. High-performance audio equipment is more likely to pick up such noise than conventional equipment because it has wide-frequency bandwidth and high-gain (amplification) circuits. The GTS100x has built-in power supply filters to help prevent noise problems. If noise occurs, it is probably the result of improper installation. The following suggestions will help you eliminate most noise problems.

Source Noise – Often, noise in a system is picked up by the signal source. Before attempting to eliminate noise from the “amp,” be sure it is not being picked up by the signal source and then passed on to the amp. To do this, connect the signal source output to an external amplifier which has no other connection to the vehicle except for the audio signal leads. A battery-powered portable with line inputs works well for this. Listen to see if the noise is present in the signal from the source unit. If so, consult the manufacturer of the source unit, or your JBL dealer, for help in eliminating this noise. If there is no noise in this signal, it can be eliminated as the source of the noise in your system.

Ground Loops – The vast majority of noise problems in car audio systems are caused by inadequate or improper grounding. The head unit, the amplifier and any other components must be grounded to a major metal member of the vehicle’s frame. Make sure to choose a solid metal ground point. In many new vehicles, some structural elements are made of plastic.

Although use of a common ground point is not usually necessary, practical experience shows that often the noise level in the system will be lower if the amplifiers and signal processors are all grounded to the same point on the chassis. Usually the head unit does not need to be grounded to the same point as the rest of the system, but in some instances grounding the head unit to the same point will also help. If this does not adequately reduce the noise level, try another ground point on the car frame. Some ground points may work better than others. In some instances with plastic-bodied vehicles,

grounding the source unit and/or amplifier directly to the battery will provide the best results, although, usually, this provides the worst results with most cars. In complex systems involving components from different manufacturers, it helps to know the type of power supplies used in each component. For low-level signal processors such as equalizers or electronic crossovers, a manufacturer may either use a power supply which is isolated through a DC-to-DC converter, or a simple regulated supply from the +12V vehicle battery.

Components using the latter type of supply can be identified by a direct connection from power ground to the shield of the RCA jacks (measured with no other connections present). For these components, the best ground connection may be one where the power ground wire is not connected at all! The RCA cables will provide the ground connection to the source unit. Please note that this is only appropriate for units which draw less than 500mA of current. Higher power units of this type are best connected with their ground wires connected directly to the chassis of the head unit. The trickiest grounding task is created when

some components of this type are mixed with other components using isolated supplies. For this type of system, the following grounding scheme will usually work:

1. Connect the head unit chassis to a solid vehicle ground using a short, heavy gauge wire (>AWG10). Do not connect this to the vehicle's wiring harness, but go directly to a metal part of the vehicle.
2. Connect all non-isolated signal-processor grounds directly to the head unit chassis at the same point. Run each wire individually. Due to wire resistance, connecting multiple wires to a single wire, then running the single wire to the head unit, is not the same!

3. Connect all amplifier and isolated signal processor grounds directly to the vehicle chassis at the same point as each other, but not necessarily to the same point as the head unit.

Power-Line Noise – The built-in power supply filter of the amplifier makes external filters unnecessary. In some cases, power supply noise can enter the system through the head unit power supply or the supply of an equalizer or other signal processor. Putting a filter on the head unit or signal processor power supply input may then be helpful.

Power wires carrying high currents may induce noise in nearby signal wires. Make sure that power wires and signal wires do not run together for long distances. When power and signal leads must cross, they should cross at right angles. If you suspect that power line noise is being induced in the signal leads, you can repeat the test for source noise described previously, but perform the test at the amplifier end of the signal cables.

Other Noise Sources – Common noise problems will be solved by proper grounding and power supply connections. However, there are many noise suppression devices (such as spark plug and coil lead suppressors and rotor and coil bypass capacitors) available at auto parts or car stereo stores. There are also noise suppressors that can be connected directly to the alternator, which are effective in some situations. The use of any such suppressors should be discussed with a JBL authorized installation specialist. Certain vehicles are particularly “noisy,” especially models that have solid-state ignition systems or that have non-metal bodies. Such vehicles may require electrical noise suppression devices which are not normally needed.

Antenna – A common noise problem is generated by a “ground loop” produced by the antenna shielded cable being grounded at both the antenna mounting point and at the head unit input. In this instance, insulate the antenna ground from the chassis of the vehicle at the antenna mounting point so the antenna shield is grounded only at the radio’s antenna input. Commercial antenna ground-loop isolators are also available.

Switching Noise – The GTS100x has a highly developed switching power supply which generates some RF interference as a result of its switch-mode operation. Although this is internally filtered and shielded by the GTS100x chassis, some unusually sensitive installations may pick up switching noise, especially when listening to weak AM radio stations. If this unusual situation occurs, one of the following installation corrections will typically eliminate the problem. 1) Relocate the amplifier to a position farther

Maintenance

away from the radio or radio antenna. 2) Move the electrical ground of the head unit and/or amp to a different point on the vehicle's chassis. 3) Keep the amplifier power supply wiring away from the radio or antenna wiring. 4) Wrap the +12 volt power supply wires for the radio/tape deck with metallized shielding tape or ground braid and ground the tape to the chassis of the vehicle.

The GTS100x does not require any regular maintenance. Periodically checking the main power supply and grounding points and terminal connections is advisable. Be sure the connections are solid and corrosion-free. Loose or corroded connections

can cause annoying intermittent noise or unusual operational problems. Do not allow dust to accumulate on the amplifier heat sinks. It will reduce the amplifier's ability to dissipate heat. Occasional vacuum cleaning will prevent dust accumulation.

Additional System Configurations for Add-On or Upgrade

30

The features and capabilities of the GTS100x provide tremendous system design flexibility. The diagrams on these pages illustrate some of the system possibilities. They are in order of increasing complexity, showing the way a system may be upgraded in logical steps. Although the systems are shown using speaker-level connection from the head unit, they may be built using any combination of speaker or preamp level inputs, depending on the capability of your head unit.

System 1

Add Power to Main Speakers

Add a GTS100x to the main (usually front) outputs of an existing head unit. Secondary speakers (usually rear-fill) connect to the head unit's internal amplification.

Next Step:
Add a second GTS100x to amplify the other set of speakers or a subwoofer (see system 2).

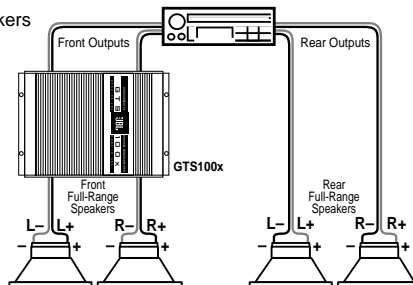

System 2A

Add a Subwoofer (Active)

Use the GTS100x to drive 1 or 2 subwoofers with the head unit powering the main speakers. This is an excellent way to upgrade a good stock system.

Next Step:
Add power to Front Full-Range Speakers (see system 3).

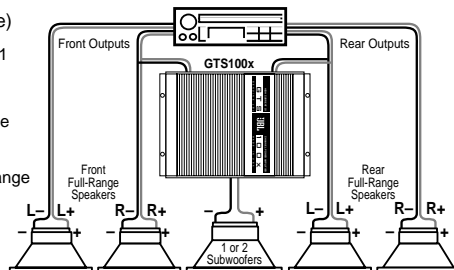

System 2B

Add a Subwoofer (Passive)

Use the GTS100x in Simultaneous Stereo + Mono mode to drive main speakers with subwoofers. A passive crossover is needed for this, as described on page 22.

Next Step:

Add a second GTS100x to power subwoofers and main speakers individually (see system 3).

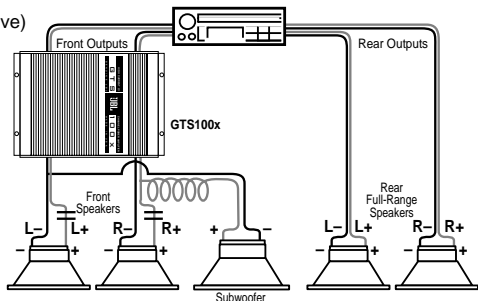

System 4

Add Power to the Rear

Add an amp for the rear speakers for higher volume capability and more control.

Next Step:

Add more subwoofer power.

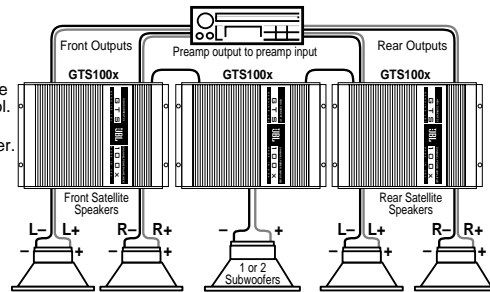

31

System 3

Add a Second GTS100x

Get more power and system control by adding a second GTS100x to power the main speakers and subwoofers individually. Use the built-in crossover to high-pass the front speakers and low-pass the subwoofers.

Next Step:

Add power to the Rear Full-Range Speakers.

Note: For non-fading bass, also connect the rear-channel head unit speaker output to the speaker level input of the subwoofer GTS100x.



System 5

Add a Second Subwoofer Amplifier

For the ultimate in bass output, add a second subwoofer amplifier for a total system power of 340 watts RMS!

Note the cross-linking of preamp inputs for the two subwoofer amplifiers to provide non-fading bass.

Next Step:

Add additional amplifiers in bridge-mode to the front and rear main speakers. Then add electronic crossovers and biamp front and rear speakers.

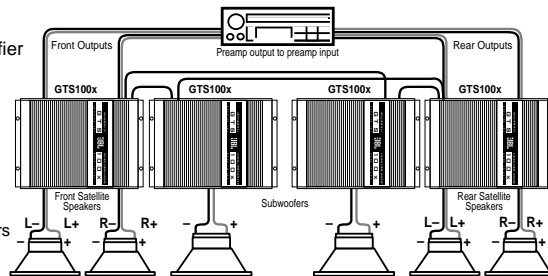

In Case of Difficulty

32

Power-on light does not come on

- Head unit not on; turn the head unit on.
- Ground wire is disconnected or defective; check for continuity with an ohmmeter between the GTS100x's ground terminal and a known chassis ground point.
- Battery wire is disconnected or defective; check for approximately +12 volts between the GTS100x's Battery and Ground terminals.
- Blown fuse; check the GTS100x's 20-amp fuse, located on the endpanel near the power connector. If it is blown, replace it with an identical one. If the new fuse blows immediately, then check all the wiring connections. If no fault is found, consult your JBL dealer.

- Remote-on wire between the head unit and the GTS100x is disconnected or defective; check for +12 volts between the GTS100x remote-on wire and the ground wire with the head unit on.
- Head unit connected to speaker-level input is not BTL high-power type and no remote wire is connected; connect remote turn-on wire to switched +12V source.

Remote-on light is illuminated, but no sound is heard from some or all of the speakers

- Incorrect switch settings; make sure that all switches (input mode, line, and crossover) are in their correct positions for your system configuration.

- Incorrectly connected or shorted speaker wires; check for shorts in wiring.
- Defective or disconnected audio cables; check for continuity and replace if necessary.
- Incorrect gain adjustment; verify that the GTS100x gain controls are not turned completely down. If they are, sound output level may be very low and may give the impression that the system (or part of the system) is dead.
- Defective head unit or signal processor; check each component for proper wiring and operation.
- Defective GTS100x; if there is audio signal present at the inputs of the GTS100x and there is no output, the GTS100x may be defective.

Alternator whine through the audio system with the engine running

- Ground loops; follow the wiring suggestions in the section called "Solving Noise Problems" (page 26). Also, verify that the chassis grounding point you have chosen is true ground by checking for continuity between the chassis ground point and battery ground.

Bass output from speakers too low.

- Speaker wired out of phase; check for proper polarity on all speaker wiring (+ amp terminal to + speaker terminal and - amp terminal to - speaker terminal).

If you want to talk to us about any problems, call JBL Customer Service at 1-800-336-4JBL between 9AM and 5PM Eastern time.

Specifications

34

Continuous Power Output (10Hz – 50kHz, 14.4V Battery Voltage, 80kHz filter)	35 watts x 2 (4 ohms, 0.05% THD) 50 watts x 2 (2 ohms, 0.08% THD) 100 watts x 1 (4 ohms, 0.08% THD)
Signal-to-Noise Ratio	100dBA
Frequency Response	10Hz – 50kHz (+0, – 1dB) 20Hz – 20kHz (+0, – 0.1dB)
Damping Factor	>200
Line-Level Input Sensitivity (for rated power)	100mV – 4V RMS (500mV nominal)
Line-Level Input Impedance	10k ohms
Speaker-Level Input Impedance	15 ohms
Speaker-Level Input Sensitivity	200mV – 8V RMS (1V nominal)
Preamp Output Sensitivity	2V out for 4V speaker-level input
Minimum Speaker Impedance	
Single Ended, Non-Bridged	2 ohms
Bridged	4 ohms
Built-In Electronic Crossover	80Hz, 18dB per octave low-pass filter
Frequency and Slope	100Hz, 18dB per octave high-pass filter
Power Requirement	11 to 16V DC negative ground
Fuse Size	20 amp ATC-type fuse
Size (L x W x H)	6-5/8" x 9-1/4" x 2" (168.3mm x 235.0mm x 50.8mm)
Weight	4lbs. 3oz. (1.90kg)
Speaker Input / Output Mating Connector	Molex Mini-Fit Jr. # 39-01-2040 Metal pins: 39-00-0038
Power Mating Connector	Plastic housing: AMP # 1-480700-0 Metal pins for ground & +12V: AMP # 350923-3 Metal pins for rem. in: AMP # 350536-1

Warranty Terms: 1 Year Transferable Limited Warranty / 2 Year Extended Transferable Limited Warranty (USA Only)

This is an important document.

Attach your bill of sale to this page and keep it in a safe place.

Your bill of sale is your warranty.

The JBL warranty remains in effect for one year from the date of the first consumer purchase unless installed by an authorized JBL dealer. Installation by an authorized JBL dealer will extend the warranty to a period of two years.

Who is Protected by this Warranty

The JBL warranty protects the original owner and all subsequent owners providing that the JBL product was purchased from an authorized dealer in the United States or purchased by military personnel from an authorized military outlet. **A copy of the original dated bill of sale must be presented whenever warranty service is required.**

What is Covered by this Warranty

Except as specified below, the JBL warranty covers all defects in material and workmanship. The following are not covered: Damage caused by accident, misuse, abuse, product modification or neglect; damage occurring during shipment; damage from failure to follow instructions contained in the instruction manual; damage resulting from the performance of repairs by someone not authorized by JBL; damage caused by installation of parts that do not conform to JBL specifications; units used for commercial or business use; any claims based on misrepresentations by the seller; products sold on an "as-is" or final sale basis; or the cost of installing, removing, or reinstalling the unit. JBL's liability is limited to the repair or replacement, at our option, of any defective product and shall not

include incidental or consequential damages. JBL reserves the right to replace a discontinued model with a comparable model. Any replacement units or parts may be new or rebuilt.

To Obtain Warranty Service

If you require warranty service, please return the product to your dealer. If this is not possible and you live in the United States, please call 1-800-336-4JBL, for information on how to obtain service or replacement. If purchased outside the United States, contact your local dealer for repair or replacement.

Do Not Return Products to the JBL Factory without Authorization.

They Will Be Returned Unopened.

You are responsible for transporting your product for repair or replacement. JBL will pay reasonable return charges for delivery to any location in the United States if the repair or replacement is covered under the warranty.

Correspondence with JBL should be addressed to: JBL Customer Service, 80 Crossways Park West, Woodbury, NY 11797 or fax us at 516-496-0812. Outside the United States, please contact your local distributor.

This warranty gives you specific legal rights. You may also have other rights which vary from state to state. Some states do not allow the exclusion or limitation of incidental or consequential damages or limitations on how long an implied warranty lasts, so the above may not apply to you.

Declaration of Conformity



We, JBL Europe A/S
Kongevejen 194B
DK-3460 Birkerød
DENMARK

declare in own responsibility, that the product described
in this owner's manual is in compliance with technical
standard:
EN 55 020/6.1988

A handwritten signature in black ink, appearing to read 'Steen Michaelsen'.

Steen Michaelsen
JBL Europe A/S
Birkerød, DENMARK, 9/96



JBL Consumer Products
80 Crossways Park West
Woodbury, NY 11797

8500 Balboa Blvd.
Northridge, CA 91329

800-336-4JBL (4525)

H A Harman International Company

Part No. JBLGTS100xOM
Made in USA

